

COMPRESSED AIR BALL FLOAT TRAPS FA17/G

DESCRIPTION

FA 17/G is a fully automatic ball float trap extremely compact in dimension and light in weight, specially designed for draining water from compressed air lines.

Applications on aftercoolers, separators and compressed air mains.

Connections are female screwed or flanged.



MAIN FEATURES

Modulating discharge.

Unaffected by sudden or wide load and pressure changes.

OPTIONS: Horizontal reversible inlet connections.

USE: Compressed air and non corrosive gas, compatible with the construction.

AVAILABLE

MODELS: FA 17/G

SIZES: DN 1/2" - 3/4"; DN 15 – DN 20.

CONNECTIONS: Female screwed ISO 7/1Rp(BS21)
Flanged EN 1092-2 PN16 or ANSI

INSTALLATION: Vertical installation.
See IMI installation and maintenance instructions.

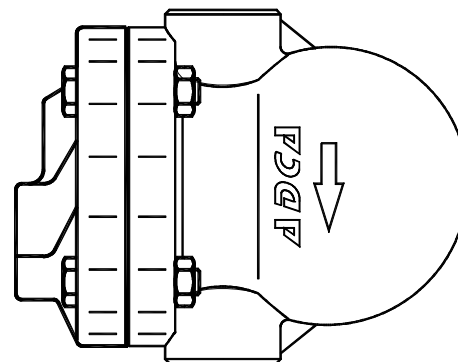

APPLICATION LIMITS

Min.Liquid specific weight	0,75 Kg/dm3
Maximum working dif.pressure	14 bar

BODY LIMITING CONDITIONS

FLANGED PN16*	FLANGED ANSI 150 **	RELATED TEMP.
ALLOW. PRES.	ALLOW. PRES.	
16 bar	15,4 bar	100 °C
15,5 bar	14,6 bar	150 °C
14,7 bar	13,8 bar	200 °C
13,9 bar	12,1 bar	250 °C

PMO - Max. operating pressure 14 bar

TMO - Max. operating temperature 200 °C

* According to EN1092-2:2000 ; ** Acc. to EN1759-1:2004

Body limiting conditions PN16 or below, depending on the type of connection adopted. Rating PN16 for thread.

FLOW RATE CAPACITY IN Kg /h

MODEL	SIZE	DIFFERENTIAL PRESSURE (bar)													
		0,5	1	1,5	2	3	4	6	7	8	9	10	12	14	
FA17G	1/2"-3/4"	120	145	180	190	230	250	300	330	340	360	380	430	430	

DIMENSIONS (mm)									
Screwed					EN PN16		ANSI 150		
SIZE DN	A	B	C	D	WGT. Kgs	F	WGT. Kgs	F	WGT. Kgs
15-1/2"	122	150	68	108	3,5	150	4,4	150	3,9
20-3/4"	122	150	68	108	3,5	150	4,9	150	4,1

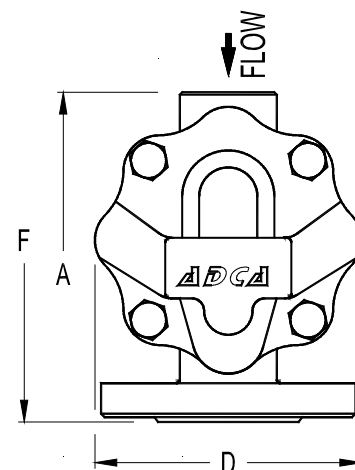
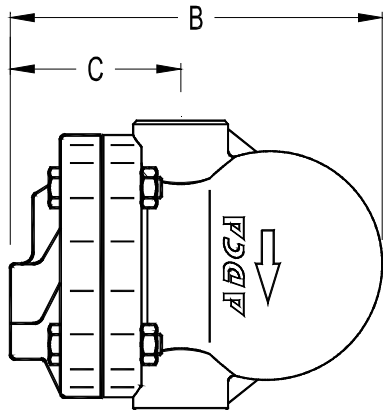

MATERIALS		
POS.Nr.	DESIGNATION	MATERIAL
1	Body	GJS-400-15 / 0.7040
2	Cover	GJS-400-15 / 0.7040
3	* Gasket	St. Steel / Graphite
4	* Seat	AISI 304 / 1.4301
5	* Valve	VITON
6	* Lever	AISI 304 / 1.4301
7	* Float	AISI 304 / 1.4301
8	Plug	A105 / 1.0432
9	Bolts	Steel 8.8

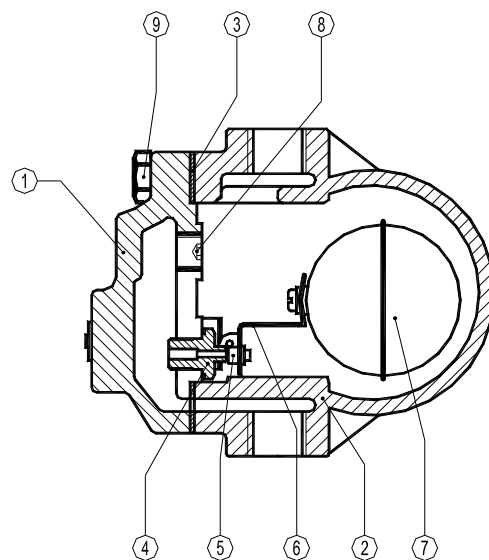

*Available spare parts.

