

Mixed Flow, Volute Casing Pump



SPL 20024...40056

TECHNICAL DATA

Output:	up to 3500 m ³ /h
Delivery head:	up to 33 m
Speed:	up to 1800 rpm depending of the pump size
Medium temperature:	max. 110 °C
Casing pressure:	max. 6 bar
Shaft sealing:	stuffing box or mechanical seal
Flange connections:	ISO DIN 2501, PN 10
Sense of rotation:	clockwise, when seen from the drive on the pump



APPLICATION

Series SPL volute-casing pumps can be used where the requirement is for pumping clean, turbid or slightly contaminated liquids. Occasional solid contaminations can be handled without affecting the pump due to the large internal cross sections.

The SPL pumps are suitable for the following applications

- pumping raw water in waterworks
- as rainwater pumps in sewage works
- for irrigation and drainage
- as seawater pumps in desalination plants
- as coolant pumps in power stations and steelworks
- for pumping low-concentration cellulose suspensions

DESIGN

The SPL is a horizontal, single stage, end suction pump flanged to a bearing pedestal. The volute casing has integral support feet and is fitted with a replaceable wear ring. Wearing parts can be removed from the drive end without disturbing the volute casing and pipework. An open impeller (designation A-I) is fitted as standard but a closed impeller (designation K-S) for pumping liquids containing abrasive solids can be fitted if required.

CONSTRUCTION

Casing pressure: between -10 °C and +110 °C

Pump size, SPL•	Maximum pump pressure [bar] (0B, 0C, 3B)	Maximum pump pressure [bar] (4B)
20024, 25024	2,5	4,0
25028, 30028, 40040	3,0	4,5
20028, 35040, 40050, 40056	3,5	5,5
25032, 30032, 30036, 35036	4,0	6,0

Note: Casing pressure = Inlet pressure + head at closed valve.

Branch positions:

Suction branch axial, discharge branch tangentially upwards.

Flanges:

Connection dimensions of flanges DIN 2532 PN 10.

Bearings:

Execution B:

Pump end--ball bearing to DIN 625 or cylindrical roller bearing to DIN 5412.

Drive end--ball bearing to DIN 625 or two angular contact ball bearings in an X arrangement to DIN 628.

Bearings are oil lubricated.

Shaft sealing:

A stuffing box or a mechanical seal, as required, can affect the sealing of the shaft.

Variants with stuffing box:

Designation 041: Self-sealing, uncooled stuffing box
Temperature range: -10 °C to 110°C.

Designation 052: Uncooled stuffing box with external sealing and flushing liquid
Temperature range: -10°C to 110°C.

Variants with mechanical seal:

The installation with mechanical seal to DIN 24960 is possible in all versions described there, as a single mechanical seal.
Temperature range: -10 °C to 110°C

- Designation AA1: Unbalanced single mechanical seal, Materials: 1.4401-carbon-Viton®
 - Designation BK3: Unbalanced single mechanical seal, Materials: Carbon-SiC- EPDM
 - Designation BKS: Unbalanced mechanical seal, Materials: SiC-SiC-Viton®
 - Designation AF3: Balanced single mechanical seal, Materials: Carbon-SiC- EPDM
 - Designation AFS: Balanced single mechanical seal, Materials: SiC-SiC-Viton®
- Double mechanical seals can be mounted on request

MATERIAL EXECUTION:

Pos.	Component	Materials execution			
		0B	0C	3B	4B
10.20 16.10	Casing, Casing cover	Cast iron		Bronze	Stainless steel
23.00	Impeller	Cast iron	Bronze		Stainless steel
51.20	Wear ring	Cast iron	Bronze		Stainless steel
21.10	Shaft	Carbon steel	Cr-steel		Stainless steel
52.40	Shaft sleeve stuffing box	Cr-steel	Stainless steel		Stainless steel
52.30	Shaft sleeve, mechanical seal	Stainless steel			
46.10	Packing	Soft packing			
43.30	Mechanical seal	Stainless steel-carbon-Viton® / Carbon-SiC- EPDM / SiC-SiC-Viton®			

Casing seal:

The casing is sealed by a o´ring

Drive / Speed:

By commercial electric motors, type of construction motor, IM B3.

For the determination of the drive power we recommend the following additions:

Up to 4 kW: 25% 4 up to 7,5 kW: 20% from 7,5 kW: 15%

The following speeds limits are to be observed:

Pump size SPL•	Max. adm. r.p.m.
200..., 250..., 300..., 35036 A, 35036 K	1800
35040,	1480
40040,	1200
35036 G, 40050, 40056,	1000

The max. speed result from the admissible shaft load and the admissible peripheral speed of the impellers

SECTIONAL DRAWING

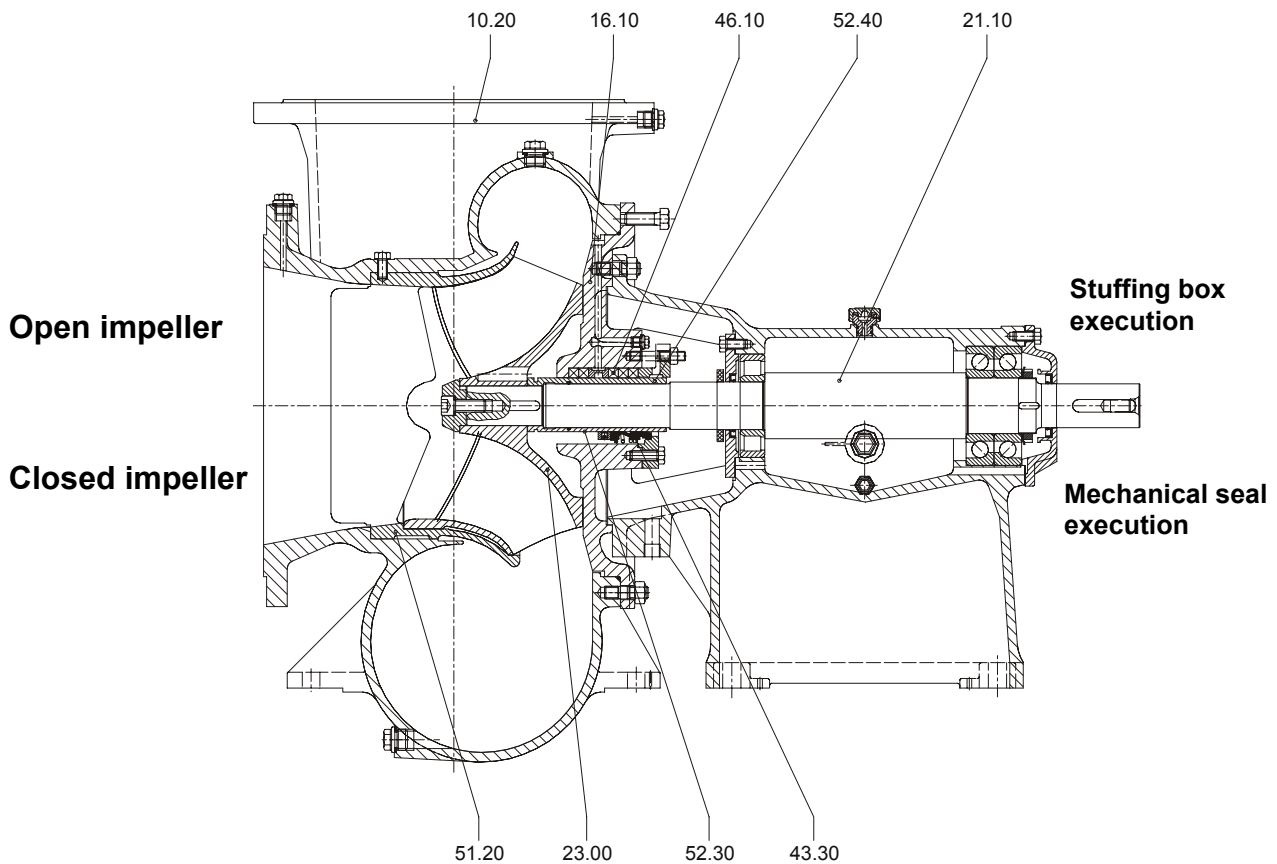

Designs are subject to amendment without prior notice.

© (Sterling Fluid Systems BV) 2004

FIELD CHARTS (open impellers)

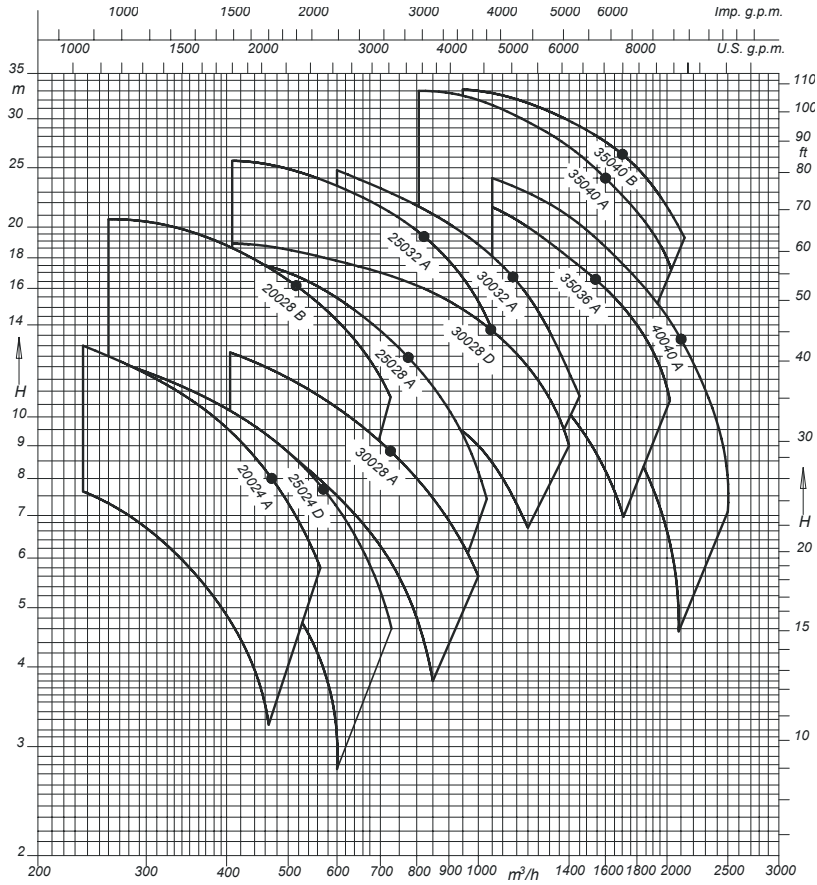

1450 rpm

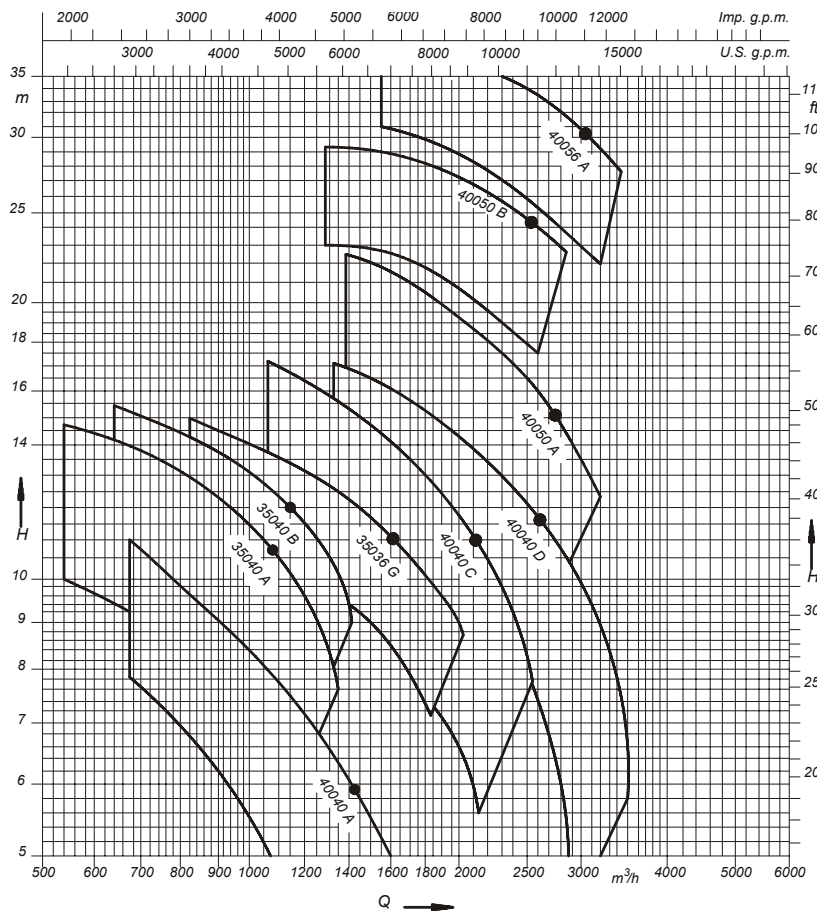

960 rpm

Designs are subject to amendment without prior notice.

© (Sterling Fluid Systems BV) 2004

FIELD CHARTS (closed impellers)

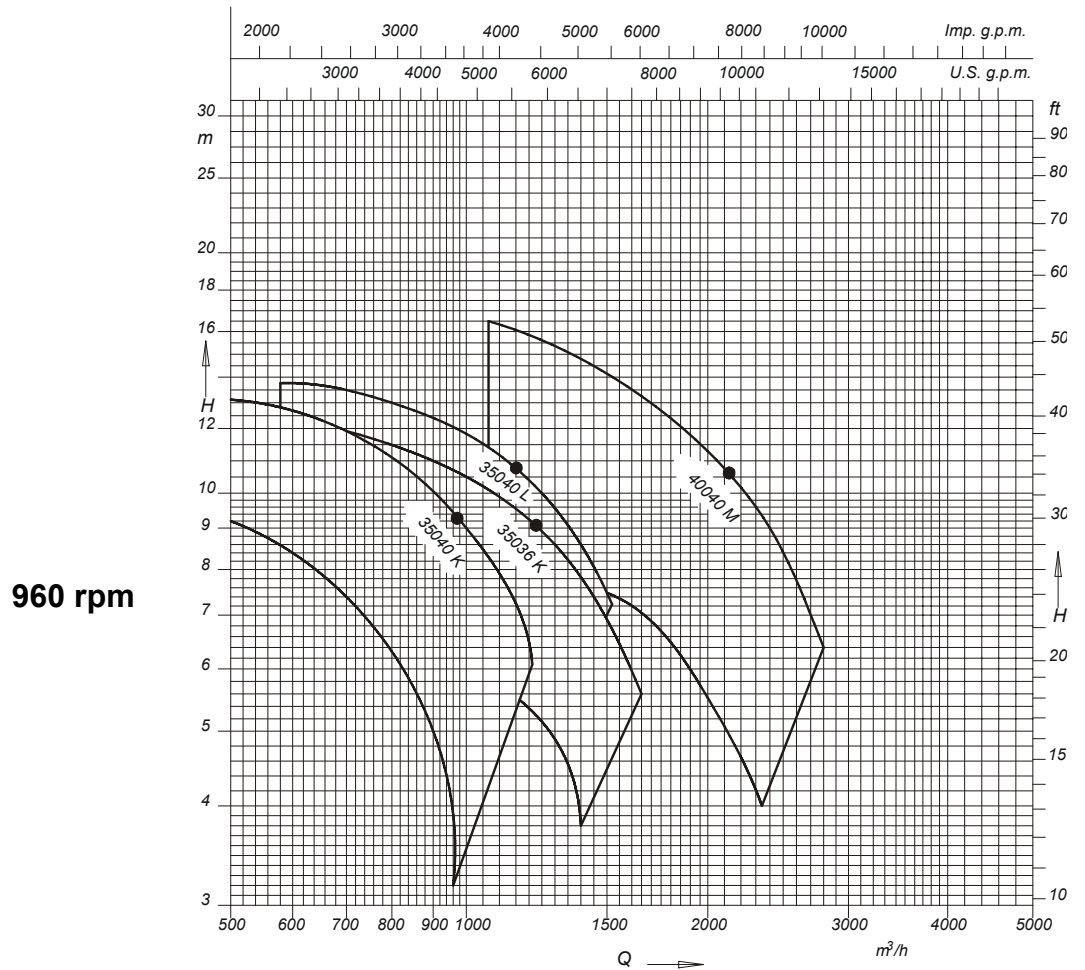
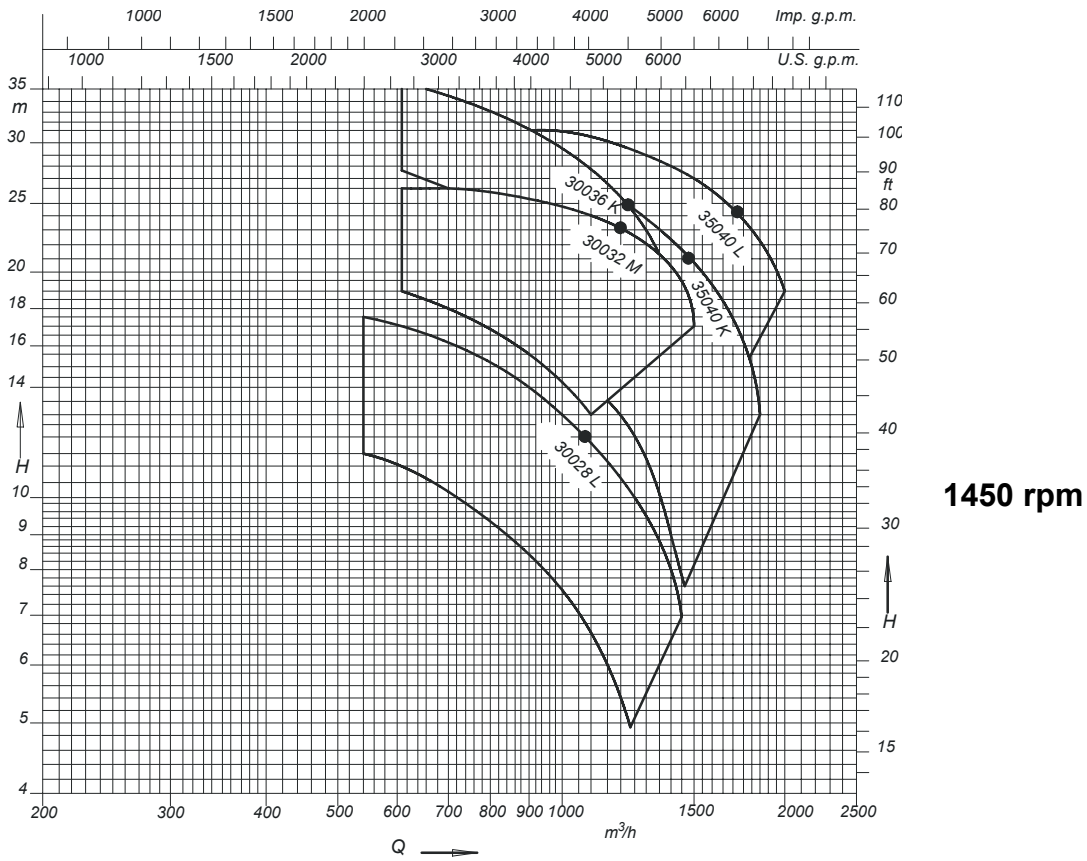

Designs are subject to amendment without prior notice.

© (Sterling Fluid Systems BV) 2004

Table of dimensions

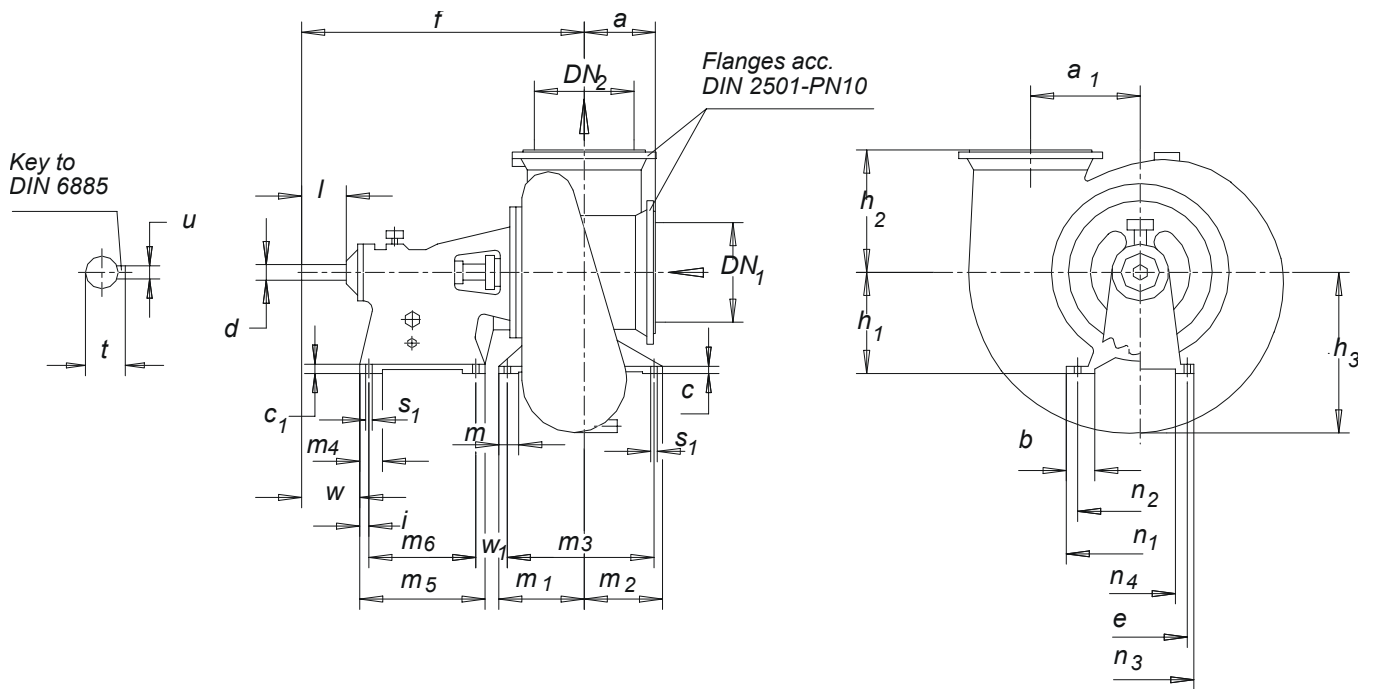

Dimensions in mm

Pump size	Supp	Pump dimensions									Foot dimensions														Shaft end							
		DN2	DN1	a	a1	f	h1	h2	h3	b	c	c1	e	i	m	m1	m2	m3	m4	m5	m6	n1	n2	n3	n4	s1	w	w1	d	l	t	u
20024	45	200	200	155	215	640	250	250	289	70	15	30	235	22,5	60	175	-	-	60	290	245	350	290	270	165	18	115	107,5	40k6	75	43	12
20028		200	200	160	195	630	250	270	267	70	15	30	235	22,5	60	165	-	-	60	290	245	350	290	270	165	18	115	107,5	40k6	75	43	12
25024		250	250	190	255	675	250	310	377	70	20	30	235	22,5	60	210	-	-	60	290	245	380	320	270	165	18	115	107,5	40k6	75	43	12
25028	50	250	250	185	250	775	280	340	336	100	25	30	290	30	70	215	180	335	80	355	295	400	320	336	210	23	155	110	45k6	100	48,5	14
25032		250	250	180	225	750	280	320	310	100	25	30	290	30	70	190	155	285	80	355	295	450	370	336	210	23	155	110	45k6	100	48,5	14
30028		300	300	220	310	800	280	350	439	100	25	30	290	30	70	240	235	415	80	355	295	480	400	336	210	23	155	110	45k6	100	48,5	14
30032		300	300	215	295	800	280	360	397	100	25	30	290	30	70	240	200	380	80	355	295	450	370	336	210	23	155	110	45k6	100	48,5	14
30036	60	300	300	220	270	815	355	385	373	100	20	32	330	32,5	-	190	160	290	80	400	335	520	440	376	246	23	147	140,5	55m6	100	59	16
35036		350	350	250	385	895	355	430	564	100	25	32	330	32,5	70	300	275	515	80	400	335	520	440	376	246	23	147	110,5	55m6	100	59	16
35040		350	350	240	330	865	355	385	448	100	20	32	330	32,5	70	260	210	410	80	400	335	520	440	376	246	23	147	120,5	55m6	100	59	16
40040	70	400	400	285	450	1045	400	550	642	110	32	35	370	35	80	345	310	585	85	445	375	700	620	416	284	23	209	116	65m6	155	69	18
40050		400	400	315	425	1020	400	550	567	110	32	35	370	35	80	320	280	530	85	445	375	700	620	416	284	23	209	116	65m6	155	69	18
40056	80	400	400	350	407	1040	475	550	556	110	30	35	420	37,5	80	290	260	480	95	490	415	700	620	472	320	27	205	127,5	75m6	155	79,5	20

Designs are subject to amendment without prior notice.

© (Sterling Fluid Systems BV) 2004

Connections

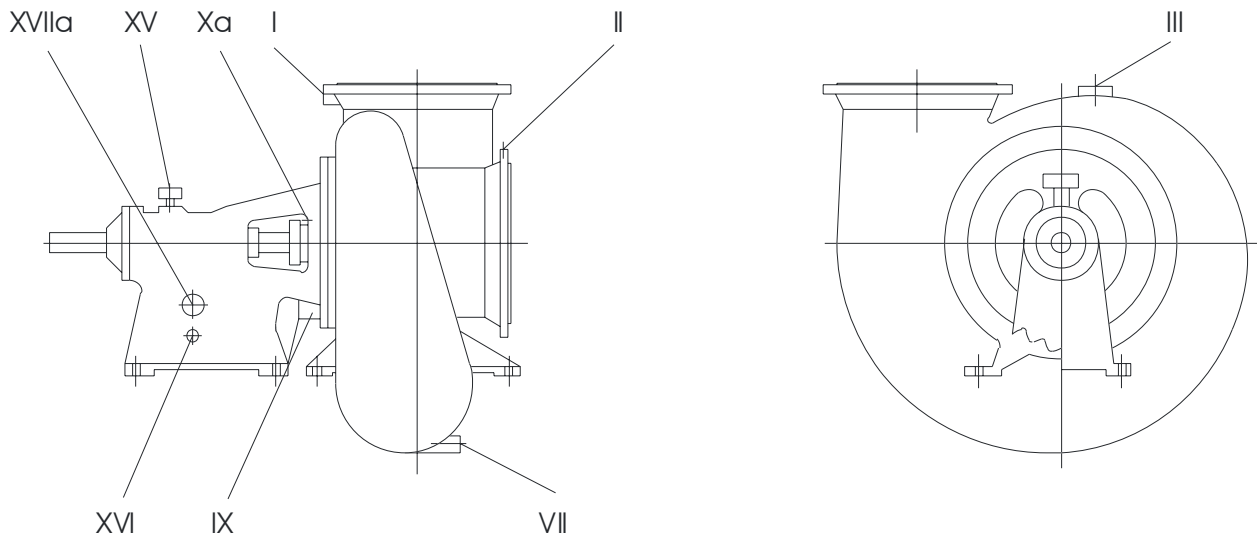

N°	CONNECTIONS	FOR EXECUTION WITH	CONNECTIONS POSITION FROM MOTOR SIDE
I	Pressure gauge connection		On delivery branch
II	Vacuum pressure gauge connection		At top of suction branch
III	Vent		At top of volute casing
VII	Drain		At bottom of volute casing, suction side
IX	Drip and leakage liquid		On the bearing pedestal bottom
Xa	Sealing liquid connection inlet	External sealing	On the casing cover, top
XV	Oil filling	Oil lubrication	On the bearing pedestal top
XVI	Oil drain	Oil lubrication	On the bearing pedestal bottom, right
XVIIa	Oil level sight glass	Oil lubrication	On the bearing pedestal right

N°	DIMENSIONS OF CONNECTIONS												
	Pump Size												
	20024	20028	25024	25028	25032	30028	30032	30036	35036	35040	40040	40050	40056
I	G 1/2												
II	G 1/2												
III	G 1/2			G 3/4									
VII	G 1/2			G 3/4									
IX	G 3/8			G 1/2									G 3/4
Xa	G 1/4												
XV	Ø20												
XVI	G 1/4						G 3/8			G 1/2			
XVIIa	G 3/4											G 1	

Foundation plan for units without spacer type coupling, SPL bearing brackets 45

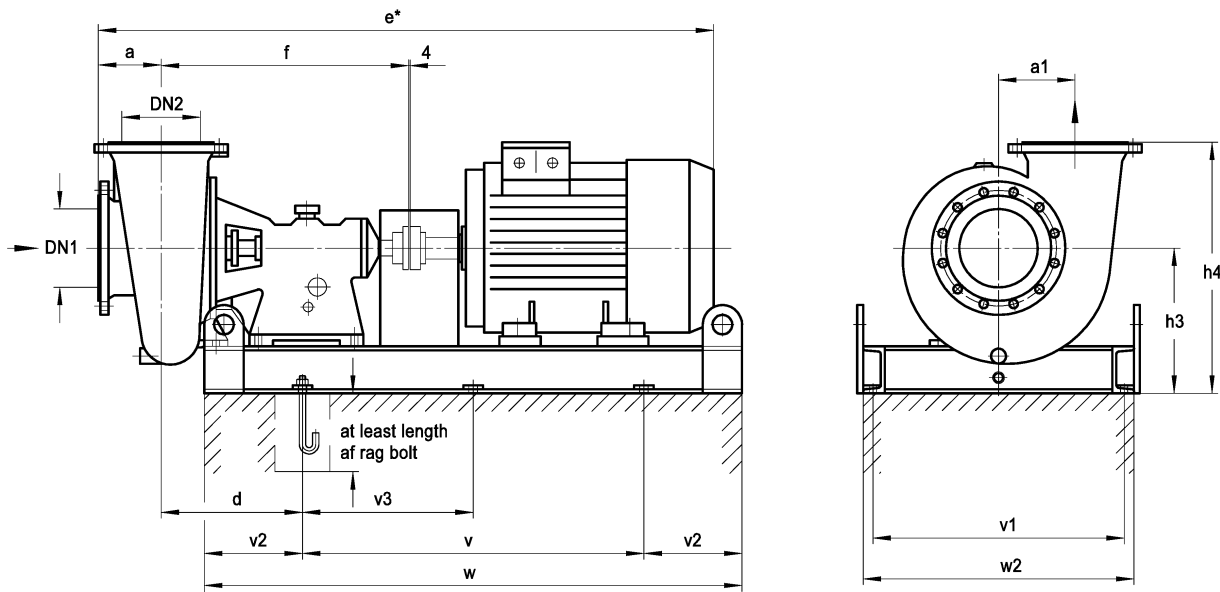

Dimensions in mm

Tolerances for welded parts acc. to DIN 8570 B

n = 1450 rpm

SPLA Size	Motor		Base plate	Cplg.	Weight (kg)				DN1	DN2	a	a1	d	e*	f	h3	h4	v	v1	v2	v3	w	w2	Rag bolt Size
	kW	Size			pump 0B,0C	pump 3B,4B	Unit* 0B,0C	Unit* 3B,4B																
20024	7.50	132M	105x46x12	B 95	190	220	425	455	200	200	155	215	220	1253	640	390	640	830	410	110	-	1050	460	M16x200
	11.00	160M	124x46x12	B 95	190	220	480	510	200	200	155	215	240	1384	640	390	640	980	410	130	490	1240	460	M16x200
	15.00	160L	124x46x12	B110	190	220	495	525	200	200	155	215	240	1384	640	390	640	980	410	130	490	1240	460	M16x200
	18.50	180M	124x46x12	B110	190	220	520	550	200	200	155	215	240	1469	640	390	640	980	410	130	490	1240	460	M16x200
20028	15.00	160L	124x46x12	B110	205	240	510	545	200	200	160	195	230	1390	630	390	660	980	410	130	490	1240	460	M16x200
	18.50	180M	124x46x12	B110	205	240	535	570	200	200	160	195	230	1464	630	390	660	980	410	130	490	1240	460	M16x200
	22.00	180L	124x46x12	B125	205	240	555	590	200	200	160	195	230	1464	630	390	660	980	410	130	490	1240	460	M16x200
	30.00	200L	124x46x12	B125	205	240	605	640	200	200	160	195	230	1514	630	390	660	980	410	130	490	1240	460	M16x200
	37.00	225S	137x55x12	B140	205	240	705	740	200	200	160	195	230	1584	630	390	660	1110	500	130	555	1370	550	M16x200
25024	7.50	132M	105x51x12	B 95	305	355	540	590	250	250	190	255	255	1323	675	390	700	830	460	110	-	1050	510	M16x200
	11.00	160M	124x51x12	B 95	305	355	610	660	250	250	190	255	275	1454	675	390	700	980	460	130	490	1240	510	M16x200
	15.00	160L	124x51x12	B110	305	355	625	675	250	250	190	255	275	1454	675	390	700	980	460	130	490	1240	510	M16x200
	18.50	180M	124x51x12	B110	305	355	650	700	250	250	190	255	275	1539	675	390	700	980	460	130	490	1240	510	M16x200
	22.00	180L	124x51x12	B125	305	355	670	720	250	250	190	255	275	1539	675	390	700	980	460	130	490	1240	510	M16x200
	30.00	200L	124x51x12	B125	305	355	720	770	250	250	190	255	275	1589	675	390	700	980	460	130	490	1240	510	M16x200

* Dimension e and weight unit depend on the motor manufacturer.

Foundation plan for units without spacer type coupling, SPL bearing brackets 60, 70, and 80

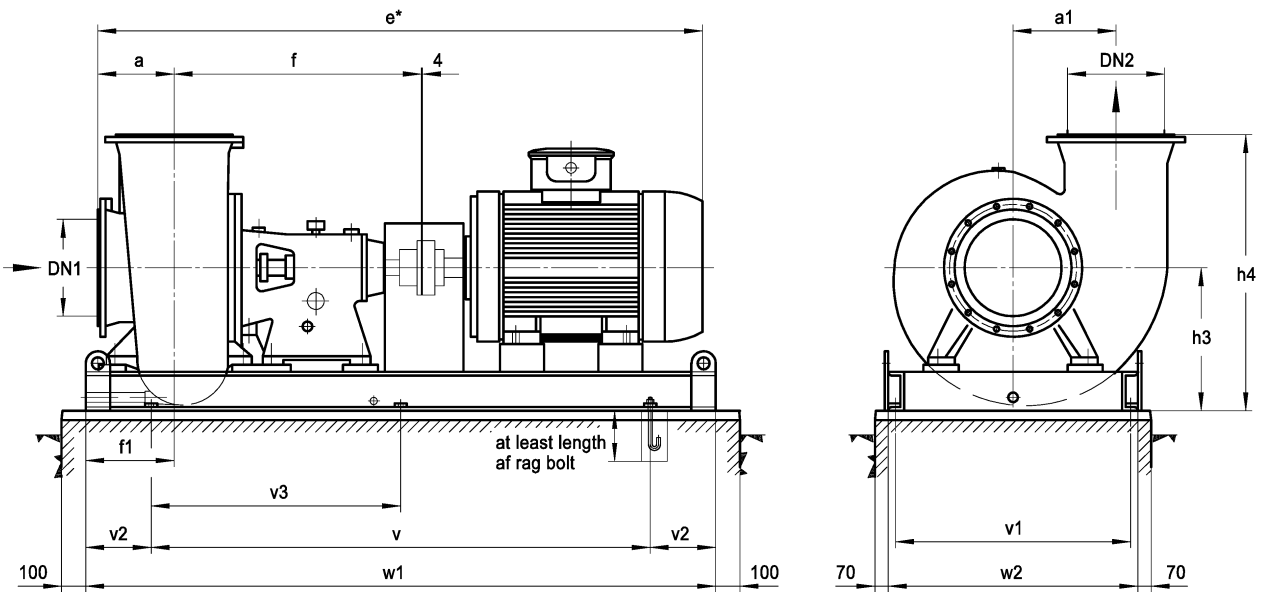

Dimensions in mm
Tolerances for welded parts acc. to DIN 8570 B

n = 960 rpm

SPLA Size	Motor		Base plate	Cplg.	Weight (kg)				DN1	DN2	a	a1	e*	f	f1	h3	h4	v	v1	v2	v3	w1	w2	Rag bolt Size
	kw	Size			0B,0C	3B,4B	Unit* 0B,0C	Unit* 3B,4B																
35036	30.00	225M	215x103x16	B140	700	810	1200	1310	350	350	250	385	1939	895	290	605	1035	1730	970	210	865	2150	1030	M16x200
	37.00	250M	215x103x16	B160	700	810	1295	1405	350	350	250	385	2039	895	290	605	1035	1730	970	210	865	2150	1030	M16x200
	45.00	280S	235x103x16	B180	700	810	1405	1515	350	350	250	385	2109	895	290	605	1035	1890	970	230	945	2350	1030	M16x200
	55.00	280M	235x103x16	B180	700	810	1440	1550	350	350	250	385	2109	895	290	605	1035	1890	970	230	945	2350	1030	M16x200
40040	75.00	315S	235x103x16	B200	700	810	1620	1730	350	350	250	385	2251	895	290	605	1035	1890	970	230	945	2350	1030	M16x200
	15.00	180L	215x88x16	B125	910	1055	1315	1460	400	400	285	450	2004	1045	325	680	1230	1730	820	210	865	2150	880	M16x200
	18.50	200L	215x88x16	B125	910	1055	1360	1505	400	400	285	450	2054	1045	325	680	1230	1730	820	210	865	2150	880	M16x200
	22.00	200L	215x88x16	B125	910	1055	1360	1505	400	400	285	450	2054	1045	325	680	1230	1730	820	210	865	2150	880	M16x200
	30.00	225M	225x88x16	B140	910	1055	1370	1515	400	400	285	450	2124	1045	325	680	1230	1790	820	230	895	2250	880	M16x200
	37.00	250M	235x88x16	B160	910	1055	1540	1685	400	400	285	450	2224	1045	325	680	1230	1890	820	230	945	2350	880	M16x200
	45.00	280S	245x88x16	B180	910	1055	1700	1845	400	400	285	450	2294	1045	325	680	1230	1950	820	250	975	2450	880	M16x200
	55.00	280M	245x88x16	B180	910	1055	1735	1880	400	400	285	450	2294	1045	325	680	1230	1950	820	250	975	2450	880	M16x200
	75.00	315S	255x88x16	B200	910	1055	1915	2060	400	400	285	450	2436	1045	325	680	1230	2050	820	250	1025	2550	880	M16x200
	90.00	315M	255x88x16	B200	910	1055	1980	2125	400	400	285	450	2436	1045	325	680	1230	2050	820	250	1025	2550	880	M16x200
40050	110	315L	265x88x16	B200	910	1055	2120	2265	400	400	285	450	2596	1045	325	680	1230	2110	820	270	1055	2650	880	M16x200
	90.00	315M	255x103x16	B200	870	1010	1940	2080	400	400	315	425	2441	1020	330	590	1140	2050	970	250	1025	2550	1030	M16x200
	110	315L	265x103x16	B200	870	1010	2080	2220	400	400	315	425	2601	1020	330	590	1140	2110	970	270	1055	2650	1030	M16x200
	132	315L	265x103x16	B200	870	1010	2170	2310	400	400	315	425	2601	1020	330	590	1140	2110	970	270	1055	2650	1030	M16x200
40056	160	315L	280x103x16	B225	870	1010	2375	2515	400	400	315	425	2741	1020	330	590	1140	2220	970	290	1110	2800	1030	M16x200
	200	315	280x103x16	B225	870	1010	2545	2685	400	400	315	425	2759	1020	330	590	1140	2220	970	290	1110	2800	1030	M16x200

Pump with power greater to 200Kw, ON REQUEST

* Dimension e and weight unit depend on the motor manufacturer.

Data regarding size - order information

Pump type + size	Hydraulic ²⁾ + Bearing	Shaft seal	Material of construction	Casing gasket
	<ul style="list-style-type: none"> • B: <u>Pump side</u>: one deep-groove ball bearing to DIN 625 or one cylindrical roller bearing to DIN 5412 <u>Drive side</u>: one deep-groove ball bearing to DIN 625 or two contact ball bearing in X arrangement to DIN 628 	041; Self - sealing, uncooled stuffing box. 052; Uncooled stuffing box for use with external sealing liquid. Single mechanical seal to DIN 24960: AA1 Unbalanced BK3 BKS AF3 Balanced AFS	0B; Main components of cast iron. 0C; As 0B, but with bronze impeller. 3B; Pump casing and impeller of bronze. 4B; Main components of stainless steel.	1; O-ring
SPL • ¹⁾ 20024 to 40056	• B	Alternatively 041, 052 AA1, BK3, BKS, AF3, AFS.	Alternatively 0B 0C 3B 4B	1

¹⁾ The dot (•) on the fourth position is substituted by the manufacturer with a character and indicates the design stage.

A: Standard execution.

Q: Variation of standard execution.

Y: Special execution.

²⁾ The dot (•) on the tenth position is substituted by the manufacturer with a character and defines the hydraulic.

A-I: Open impellers.

K-S: Closed impellers.

STERLING

