

Volute Casing Pump

additional sizes to those of ISO 2858/EN 22858



CBT• 100160...350400

TECHNICAL DATA

Output:	up to 2200 m ³ /h
Delivery head:	up to 160 m
Speed:	max. 1500 until 3000 rpm depending of the pump size and material execution
Medium temperature:	max. 350 °C
Casing pressure:	until 25 bar
Shaft sealing:	stuffing box or mechanical seal
Flange connections:	PN 16 or PN 25 Optional drilled PN 40, ANSI RF 150 or ANSI RF 300
Sense of rotation:	clockwise, when seen from the drive on the pump

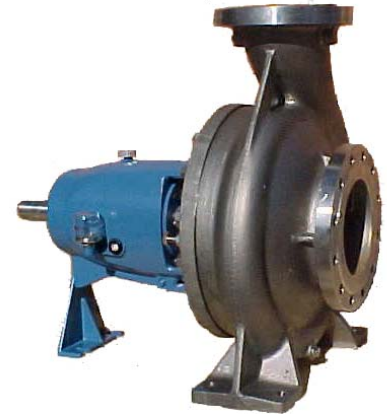

APPLICATION

Series CBT• volute-casing pumps can be used where the requirement is for pumping of clear or slightly dirty or even corrosive liquids.

Series CBT• pumps are therefore suitable for use in the:

- chemical and petrochemical industries
- pharmaceutical industries
- plastic and rubber industries
- ferrous and non-ferrous metal industries
- paper and cellulose industries
- textile industries
- food and drink industries
- thermal power stations
- municipal water supply and irrigation

particularly in applications in:

- all processing plants,
- pumping of acids, brine and alkalis and all types of hydrocarbons,
- surface treatment and surfacing hardening of metal, e. g. galvanizing, anodizing, phosphatizing,
- desalination and extractions plants,
- in heating engineering for circulation of water and other heat transfer fluids,
- water treatment and supply,
- treatment of industrial effluents.

DESIGN

Process type, single-stage, volute casing pumps with design features and nominal rating to ISO2858/EN22858. For pumping of liquids with high temperatures ($\geq 200^{\circ}\text{C}$) special executions with centre line feet are available (RBT•) upon request.

The process design permits dismantling of the complete bearing unit towards the drive end, without the pump casing having to be disconnected from the piping. If a spacer coupling is used it is also unnecessary to disconnect the motor.

The list comprises 20 pump sizes, with maximum interchangeability, these are covered with four bearing housing sizes.

CONSTRUCTION

Sizes with single volute casing:

100160, 125200, 150200, 150315, 150400, 150500
200250, 200315, 250300, 250315

Sizes with single volute casing with diffuser:

150630, 200630

Sizes with double volute casing:

Remaining sizes.

Casing pressure:

Material execution:	GG	GGG	Stainless steel
Temperature: -10 to 120 °C	16	25	16
Temperature: -20 to 120 °C		25	16
Temperature: 120 to 200 °C		16	10

Please note:

Casing pressure = Inlet pressure + shut off head.

max test pressure = **GGG** 33 bar; **GG and SS** 21 bar

Branch positions:

Suction branch axial, discharge branch radially upwards.

Flanges:

DIN 2533 PN 16 for GG25.

DIN 2534 PN 25 for GGG-40.3.

DIN 2543 PN 16 for stainless steel.

Flanges can be supplied drilled to ANSI

Bearings:

One oil lubricated deep groove ball bearing to DIN 625 on the pump end, two single-row angular contact ball bearings in an O arrangement on the drive end.

- Oil level control by constant level oiler as standard.
- Bearing brackets are optional equipped with tapped holes for installation of temperature/vibration sensors.
- Oil bath cooling can be provided.

Shaft sealing:

The sealing of the shaft can be effected by a stuffing box or a mechanical seal, as required.

Variants with stuffing box:

Designation 021: Uncooled stuffing box with external sealing (inlet only).
Temperature range: up to 110°C.

Designation 041: Self-sealed uncooled stuffing box.
Temperature range: up to 110°C.

Designation 501: Stuffing box designed for intensive cooling.
Temperature range: up to 210°C

Designation 521: As 021 but with cooling jacket on casing cover.
Temperature range: up to 350°C.

Attention: Not all of the shaft sealing executions may be available for all sizes.

Variants with mechanical seal:

The installation with mechanical seal to DIN 24960 is possible in all versions described there, as a single mechanical seal, double mechanical seal and mechanical seal with a stationary spring element.

Double mechanical seals can be mounted in back-to-back or tandem arrangement. On all versions the seal cover plates can be provided with a hole for draining the leakage, and with a quench connection incorporating a throttling bush.

Designation BK3: Unbalanced mechanical seal,
Materials: Graphite-SiC- EPDM
Temperature range: -20 to 120 °C
Pressure range up to 16 bar

Designation BKS: As BK3, but with SiC-SiC-Viton®
Temperature range: -20 to 120 °C
Pressure range up to 16 bar

Other shaft seals upon request.

MATERIAL EXECUTION:

Pos.	ITEMS	MATERIAL EXECUTION							
		0B	0G*	1A	1G*	2A	2G*	4B	F1
10.20	Casing	GG-25		GGG-40.3		GS-C25		1.4408	1.4517
16.10	Casing cover	GG-25		GGG-40.3		GS-C25		1.4408	1.4517
33.00	Bearing bracket	GG-25							
21.00	Shaft	CK 45 N							
23.00	Impeller	GG-25	GGG-50	GG-25	GGG-50	GG-25	GGG-50	1.4408	1.4517
50.20	Wear ring	GGZ-25						1.4408	1.4517
52.40	Shaft sleeve	1.4122						1.4571	1.4462

* Material executions 0G, 1G, 2G only for impeller diameters 630

Casing seals:

The casing is sealed by flat seal of synthetic fibre (Code 3), Optional PTFE (Code 2), or special graphite (Code 4). For pumps sizes 150630, 200630 and 250630 the casing is sealed by O-ring of Perbunan (Code P), Viton (Code V), EPDM (Code E).

Drive / Speed:

By commercial electric motors, type of construction, IM B3.

For the determination of the drive power we recommend the following additions:

up to 4 kW: 25%

4 up to 7,5 kW: 20%

from 7,5 kW: 15%

The following speeds limits are to be observed:

Max. speed rpm	Size	Max. speed rpm	Size	Max. speed rpm	Size
3000	100160	1800	125200	1500	150500
			150200		250400
			150315		250500
			150400		250630
			200250		300400
			200315		300500
			250300		350400
				250315	

The max. speed result from the admissible shaft load and the admissible peripheral speed of the impellers

General comments:

Regarding horizontal single stage volute pumps as per dimensions ISO2858/EN22858 and meeting the technical requirements of ISO5199/EN25199, we refer to standard chemical pumps program of the SIHI^{isochem}.

SECTIONAL DRAWING AND PARTS LIST

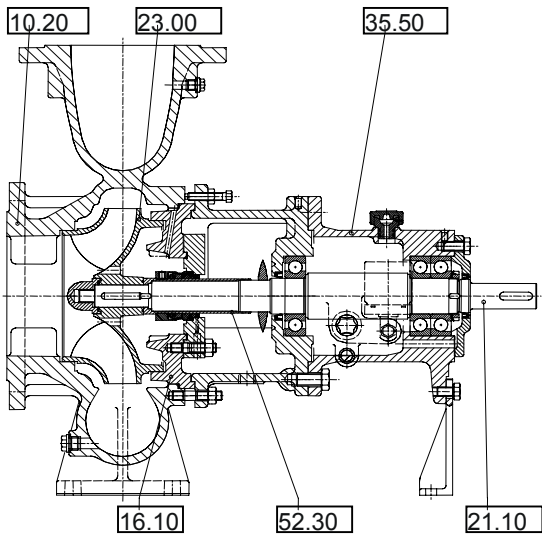

Single volute casing pumps; bearing bracket 45 B

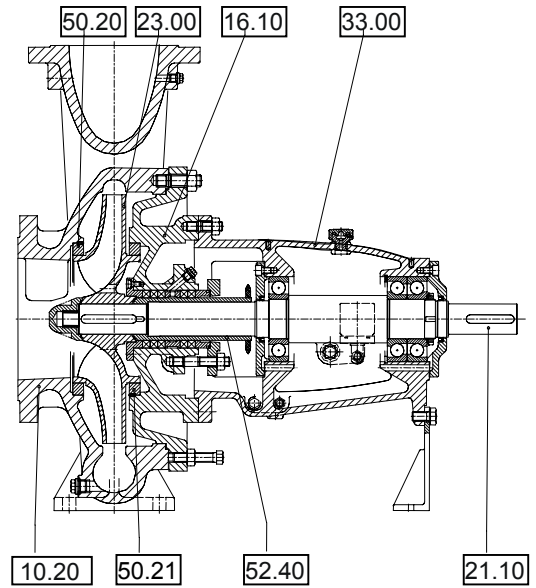

Single volute casing pumps; bearing bracket 55

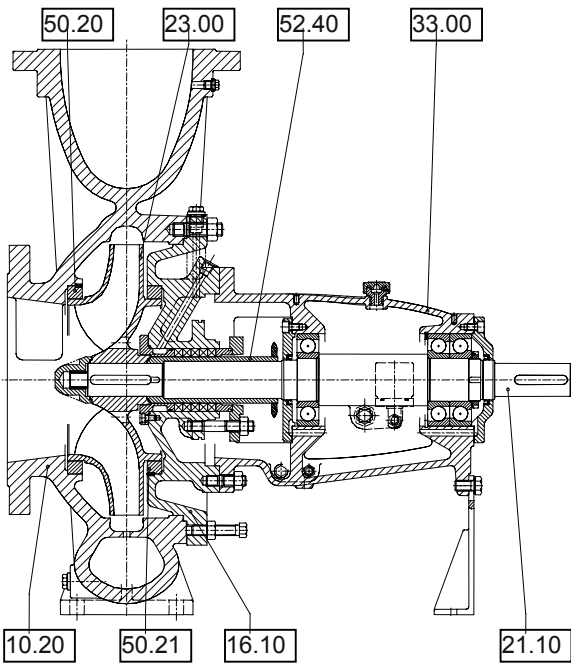

Double volute casing pumps

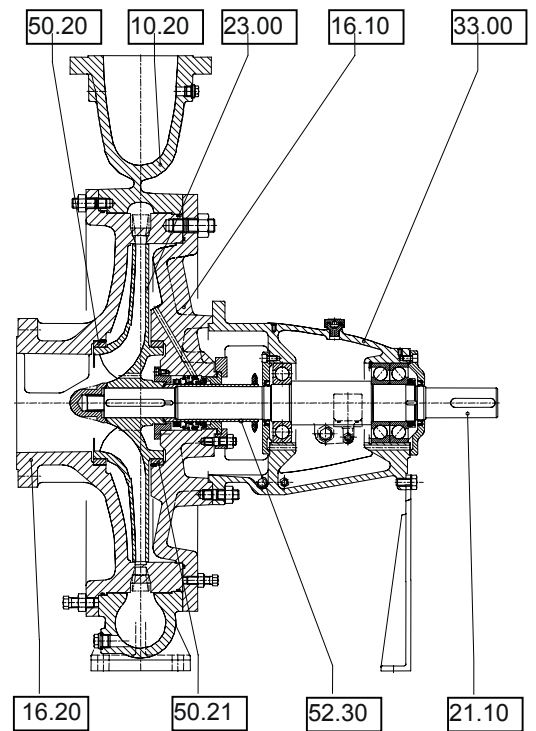

Pumps with diffuser

PARTS LIST

10.20	Casing	33.00, 35.50	Bearing bracket
16.10, 16.20	Casing cover	50.20, 50.21	Wear ring
21.00	Shaft	52.30	Shaft sleeve for mechanical seal
23.00	Impeller	52.40	Shaft sleeve for packing

DIMENSIONS

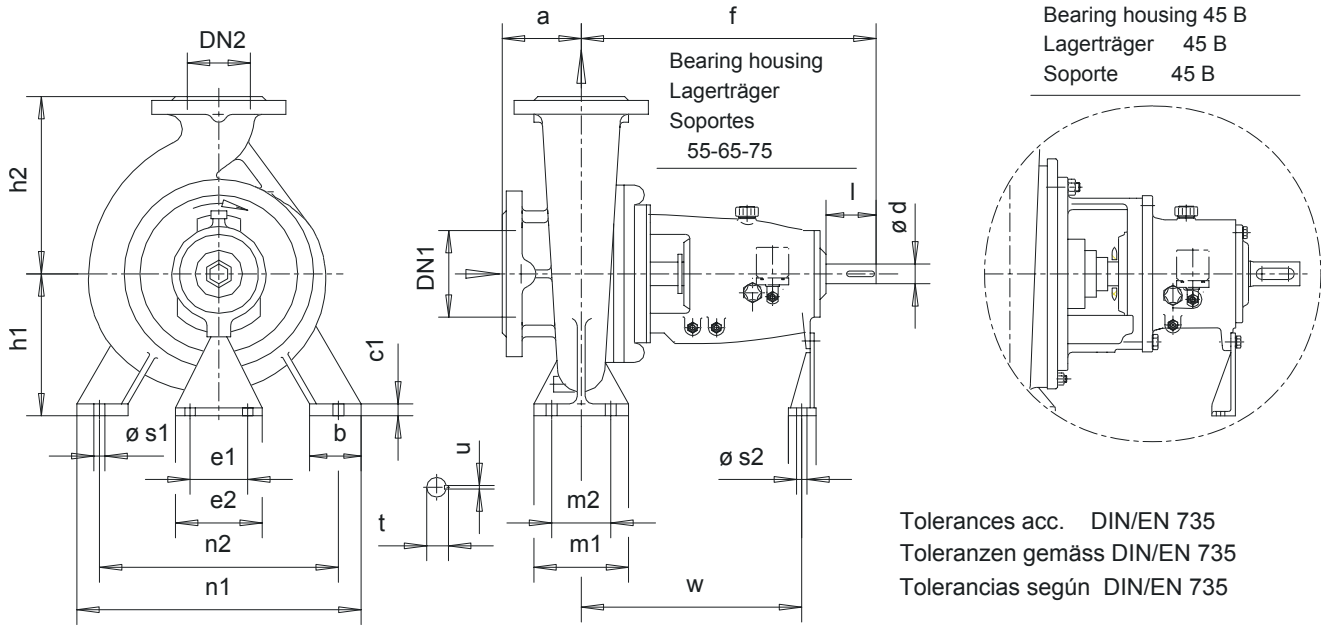

Dimensions in mm./Maße in mm./Dimensiones en mm.

Size	Bearing bracket	Pump						Feet										Shaft				Weight kg. (GG-25)	
		DN2	DN1	a	f	h1	h2	b	c1	m1	m2	n1	n2	s1	s2	e1	e2	w	d	l	t		u
100160	45 B	100	125	125	500	200	280	80	16	160	120	340	260	18	15	110	140	370	32	80	35	10	96
125200	45 B	125	150	140	500	250	315	80	18	160	120	400	315	18	15	110	140	370	32	80	35	10	123
150200	45 B	150	200	160	500	280	400	100	20	200	150	550	450	22	15	110	140	370	32	80	35	10	153
150315	55	150	200	160	670	315	400	100	22	200	150	550	450	23	18	140	200	489	50	110	53,5	14	280
150400	55	150	200	160	670	315	450	100	22	200	150	550	450	23	18	140	200	489	50	110	53,5	14	310
150500	55	150	200	180	670	400	500	100	22	200	150	640	540	23	18	140	200	489	50	110	53,5	14	350
150630	65	150	200	250	720	540	700	160	30	200	150	1000	880	23	18	140	200	508	60	140	64	18	860
200250 ³⁾	55	200	200	180	720	355	425	100	22	200	150	550	450	23	18	140	200	539	50	110	53,5	14	300
200315	55	200	250	200	670	355	450	100	22	200	150	550	450	23	18	140	200	489	50	110	53,5	14	310
200400	55	200	250	180	670	355	500	100	22	200	150	550	450	23	18	140	200	489	50	110	53,5	14	350
200500 ¹⁾	55	200	250	200	670	425	560	100	22	200	150	660	560	23	18	140	200	489	50	110	53,5	14	400
200630	75	200	250	250	760	600	750	160	30	200	150	1100	980	23	18	140	200	518	75	170	80	22	900
250300	55	250	300	305	655	425	550	120	28	240	190	700	600	23	18	140	200	474	50	110	53,5	14	416
250315	55	250	300	250	670	375	560	120	28	240	190	620	520	23	18	140	200	489	50	110	53,5	14	425
250400	65	250	300	250	720	400	600	120	28	240	190	700	600	23	18	140	200	508	60	140	64	18	465
250500	65	250	300	250	720	450	670	120	28	240	190	750	650	23	18	140	200	508	60	140	64	18	590
250630	75	250	300	250	760	560	750	160	35	260	200	1050	950	27	18	140	200	518	75	170	80	22	965
300400	65	300	350	300	720	425	670	120	30	250	190	760	660	27	18	140	200	508	60	140	64	18	620
300500	65	300	350	300	720	480	670	140	30	250	190	840	720	27	18	140	200	508	60	140	64	18	805
350400	65	350	400	300	715	525	700	140	30	300	220	900	800	27	18	140	200	508	60	140	64	18	865

- 1) Discharge flange 12 x threaded drillings/M20 (Only for PN 16 flanges)
- 2) Weights are approx.
- 3) Pump denomination CBTE

TABLE OF CONECTIONS

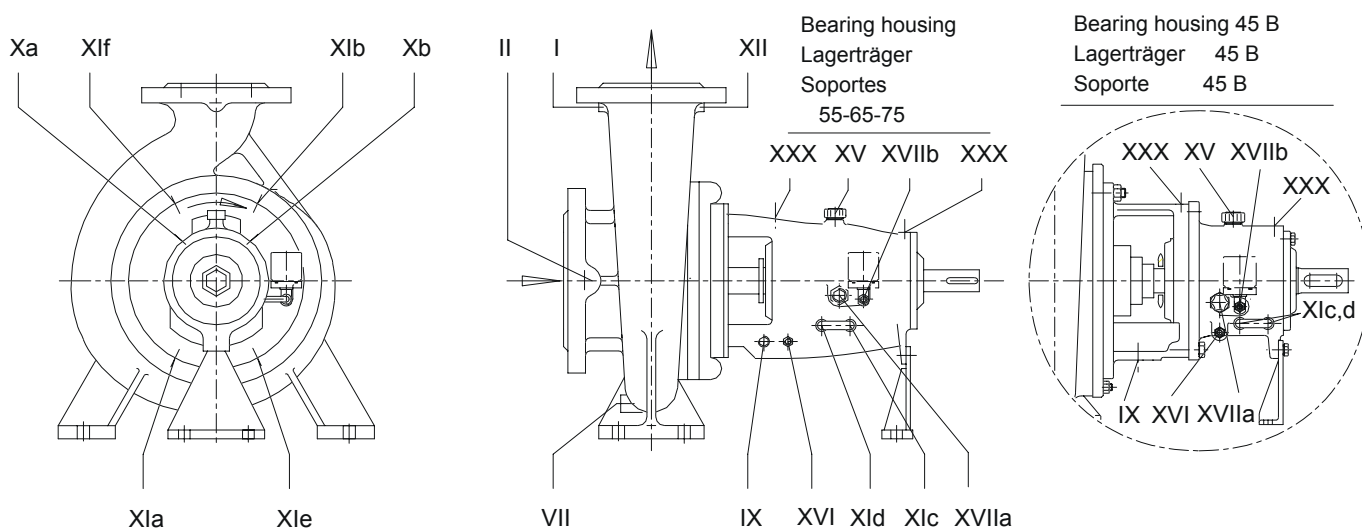

Pos.	Connections	Bearing bracket			
		45 B	55	65	75
I	Pressure gauge	G 1/4" ¹⁾	G 1/2" ¹⁾	G 1/2" ¹⁾	G 1/2" ¹⁾
II	Pressure/vacuum gauge	G 1/4" ¹⁾	G 1/2" ¹⁾	G 1/2" ¹⁾	G 1/2" ¹⁾
VII	Drain	G 3/8"	G 1/2"	G 1/2" ²⁾	G 3/4"
IX	Leakage liquid connection	G 1/2"	G 1/2"	G 1/2"	G 1/2"
Xa	Sealing liquid - inlet	G 1/4" ⁴⁾	G 1/4" ⁴⁾	G 1/4" ⁴⁾	G 1/4" ⁴⁾
Xb	Sealing liquid - outlet	G 1/4" ⁴⁾	G 1/4" ⁴⁾	G 1/4" ⁴⁾	G 1/4" ⁴⁾
Xla ⁶⁾	Shaft seal cooling - inlet	G 3/8" ⁴⁾	G 1/2" ⁴⁾	G 1/2" ⁴⁾⁵⁾	-
Xlb ⁶⁾	Shaft seal cooling - outlet	G 3/8" ⁴⁾	G 1/2" ⁴⁾	G 1/2" ⁴⁾⁵⁾	-
Xlc	Bearing cooling - inlet	G 3/8" ¹⁾	G 3/8" ¹⁾	G 3/8" ¹⁾	G 3/8" ¹⁾
Xld	Bearing cooling - outlet	G 3/8" ¹⁾	G 3/8" ¹⁾	G 3/8" ¹⁾	G 3/8" ¹⁾
Xle ⁶⁾	Intensive cooling - inlet	G 1/4" ⁴⁾	G 3/8" ⁴⁾	G 3/8" ⁴⁾	G 3/8" ⁴⁾
Xlf ⁶⁾	Intensive cooling - outlet	G 1/4" ⁴⁾	G 3/8" ⁴⁾	G 3/8" ⁴⁾	G 3/8" ⁴⁾
XII	External circulation	G 1/4"	G 1/4"	G 1/4" ³⁾	G 1/2"
XV	Oil filling	Ø 20	Ø 20	Ø 20	Ø 20
XVI	Oil draining	G 1/4"	G 1/4"	G 1/4"	G 1/4"
XVIIa	Oil level sight glass	G 3/4"	G 3/4"	G 3/4"	G 3/4"
XVIIb	Constant level oiler	G 1/4"	G 1/4"	G 1/4"	G 1/4"
XXX	Sensor connection	M 8	M 8	M 8	M 8

- 1) On request
- 2) For sizes 150630 and 350400 – G3/4"
- 3) For sizes 150630 and 350400 – G1/2"
- 4) Depending of the shaft seal arrangement
- 5) No available for sizes 150630 and 350400
- 6) No available for CBTE 200250

Foundation plan for units with spacer type coupling, CBTA bearing brackets 45B.

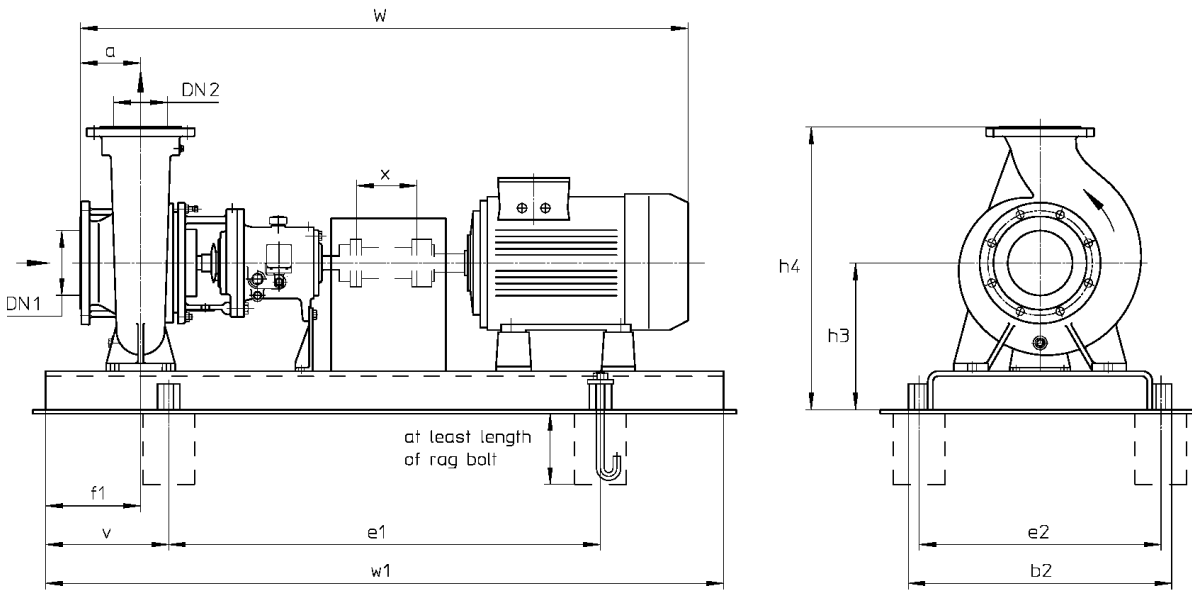

Dimensions in mm
Tolerances for welded parts acc. to DIN 8570B

CBTA Size	Motor rpm		Base plate No.	Cplg.	Weight (kg)		DN ₂	DN ₁	a	b ₂	v	e ₁	e ₂	f ₁	h ₃	h ₄	x	w*	w ₁	Rag bolt size	
	1450 KW	2900 KW			Size	pump															Unit*
100160	2.20	-	100L	S385	H 95	96	196	100	125	125	490	200	740	440	90	280	560	140	1137	1140	M20x250
	3.00	-	100L	S385	H 95	96	200	100	125	125	490	200	740	440	90	280	560	140	1137	1140	M20x250
	4.00	-	112M	S385	H 95	96	208	100	125	125	490	200	740	440	90	280	560	140	1158	1140	M20x250
	5.50	-	132S	S385	H 95	96	218	100	125	125	490	200	740	440	90	280	560	140	1218	1140	M20x250
	-	15.00	160M	S487	H110	96	312	100	125	125	610	240	940	550	90	300	580	140	1353	1420	M24x400
	-	18.50	160L	S487	H110	96	322	100	125	125	610	240	940	550	90	300	580	140	1353	1420	M24x400
	-	22.00	180M	S487	H125	96	355	100	125	125	610	240	940	550	90	300	580	140	1435	1420	M24x400
	-	30.00	200L	S487	H125	96	415	100	125	125	610	240	940	550	90	300	580	140	1485	1420	M24x400
-	37.00	200L	S487	H125	96	435	100	125	125	610	240	940	550	90	300	580	140	1485	1420	M24x400	
125200	5.50	-	132S	S486	H 95	123	267	125	150	140	610	205	840	550	90	350	665	140	1234	1250	M24x400
	7.50	-	132M	S486	H 95	123	274	125	150	140	610	205	840	550	90	350	665	140	1234	1250	M24x400
	11.00	-	160M	S487	H 95	123	332	125	150	140	610	240	940	550	90	350	665	140	1368	1420	M24x400
	15.00	-	160L	S487	H110	123	348	125	150	140	610	240	940	550	90	350	665	140	1368	1420	M24x400
	18.50	-	180M	S487	H110	123	374	125	150	140	610	240	940	550	90	350	665	140	1450	1420	M24x400
150200	5.50	-	132S	S607	H 95	153	335	150	200	160	730	230	940	670	110	380	780	140	1254	1400	M24x400
	7.50	-	132M	S607	H 95	153	342	150	200	160	730	230	940	670	110	380	780	140	1254	1400	M24x400
	11.00	-	160M	S607	H 95	153	380	150	200	160	730	230	940	670	110	380	780	140	1388	1400	M24x400
	15.00	-	160L	S607	H110	153	396	150	200	160	730	230	940	670	110	380	780	140	1388	1400	M24x400
	18.50	-	180M	S607	H110	153	422	150	200	160	730	230	940	670	110	380	780	140	1470	1400	M24x400

* Dimension w and weight unit depend on the motor manufacturer.

Foundation plan for units with spacer type coupling, CBTA bearing brackets 55, 65 & 75

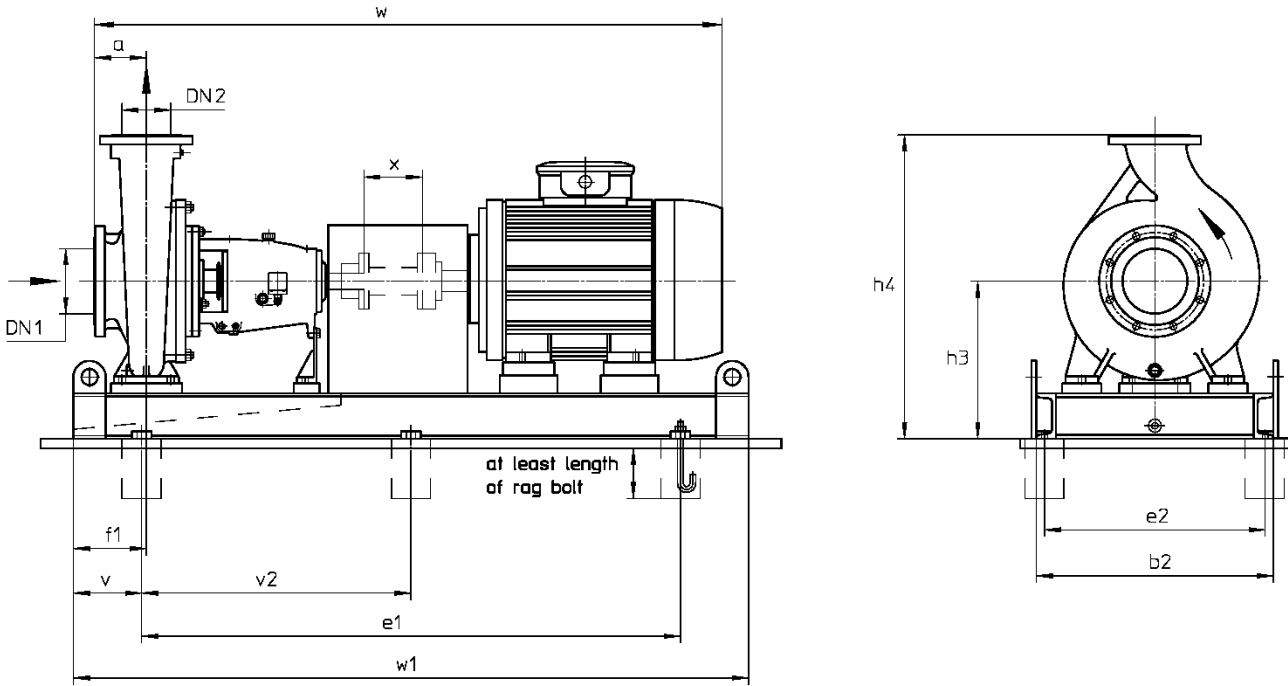

Dimensions in mm

Tolerances for welded parts acc. to DIN 8570 B

n = 1450 rpm

CBTA Size	Motor		Base plate No.	Cplg.	Weight kg		DN ₂	DN ₁	a	b ₂	v	e ₁	e ₂	v ₂	f ₁	h ₃	h ₄	x	w*	w ₁	Rag bolt
	kW	size			pump	Unit*															
150315	22.00	180L	180x73x14	H125	280	695	150	200	160	730	190	1420	680	710	200	485	885	180	1680	1800	M16x250
	30.00	200L	194x73x14	H125	280	750	150	200	160	730	190	1560	680	780	200	485	885	180	1730	1940	M16x250
	37.00	225S	196x73x14	H140	280	800	150	200	160	730	190	1580	680	790	200	485	885	180	1800	1960	M16x250
	45.00	225M	196x73x14	H140	280	840	150	200	160	730	190	1580	680	790	200	485	885	180	1800	1960	M16x250
150400	55.00	250M	208x73x14	H160	280	930	150	200	160	730	210	1660	680	830	200	485	885	180	1900	2080	M16x250
	45.00	225M	196x73x14	H140	310	870	150	200	160	730	190	1580	680	790	200	485	935	180	1800	1960	M16x250
	55.00	250M	208x73x14	H160	310	960	150	200	160	730	210	1660	680	830	200	485	935	180	1900	2080	M16x250
	75.00	280S	215x74x14	H180	310	1115	150	200	160	740	210	1730	690	865	200	485	935	180	1970	2150	M16x250
150500	90.00	280M	215x74x14	H180	310	1160	150	200	160	740	210	1730	690	865	200	485	935	180	1970	2150	M16x250
	55.00	250M	208x82x16	H160	350	1005	150	200	180	820	210	1660	770	830	240	570	1070	180	1920	2080	M16x250
	75.00	280S	215x82x16	H180	350	1165	150	200	180	820	210	1730	770	865	240	570	1070	180	1990	2150	M16x250
	90.00	280M	215x82x16	H180	350	1210	150	200	180	820	210	1730	770	865	240	570	1070	180	1990	2150	M16x250
150630	110	315S	230x83x16	H200	350	1395	150	200	180	830	230	1840	770	920	245	590	1090	180	2132	2300	M18x350
	132	315M	230x83x16	H200	350	1475	150	200	180	830	230	1840	770	920	245	590	1090	180	2132	2300	M18x350
	110	315S	240x120x18	H200	860	2085	150	200	250	1200	250	1900	1140	950	310	750	1450	180	2252	2400	M18x350
	132	315M	240x120x18	H200	860	2165	150	200	250	1200	250	1900	1140	950	310	750	1450	180	2252	2400	M18x350
200250	160	315L	255x120x18	H200	860	2315	150	200	250	1200	250	2050	1140	1025	310	750	1450	180	2412	2550	M18x350
	200	315L	255x120x18	H200	860	2420	150	200	250	1200	250	2050	1140	1025	310	750	1450	180	2412	2550	M18x350
	250	315	270x120x18	H225	860	2680	150	200	250	1200	270	2200	1140	1100	310	750	1450	180	2550	2700	M18x350
	315	315	270x120x18	H250	860	2895	150	200	250	1200	270	2200	1140	1100	310	750	1450	180	2550	2700	M18x350
200315	15.00	160L	180x73x12	H110	300	650	200	200	180	730	190	1420	680	710	240	495	920	180	1668	1800	M16x250
	18.50	180M	186x73x12	H110	300	680	200	200	180	730	190	1480	680	740	240	495	920	180	1750	1860	M16x250
	22.00	180L	186x73x12	H125	300	700	200	200	180	730	190	1480	680	740	240	495	920	180	1750	1860	M16x250
	30.00	200L	194x73x14	H125	300	770	200	200	180	730	190	1560	680	780	240	515	940	180	1800	1940	M16x250
200400	30.00	200L	194x73x14	H125	310	780	200	250	200	730	190	1560	680	780	260	525	975	180	1820	1940	M16x250
	37.00	225S	198x73x14	H140	310	835	200	250	200	730	190	1600	680	800	260	525	975	180	1857	1980	M16x250
	45.00	225M	198x73x14	H140	310	870	200	250	200	730	190	1600	680	800	260	525	975	180	1857	1980	M16x250
	55.00	250M	210x73x14	H160	310	965	200	250	200	730	210	1680	680	840	260	525	975	180	1980	2100	M16x250
200400	75.00	280S	217x74x14	H180	310	1100	200	250	200	740	210	1750	690	875	260	525	975	180	2055	2170	M16x250
	45.00	225M	196x73x14	H140	350	910	200	250	180	730	190	1580	680	790	240	525	1025	180	1820	1960	M16x250
	55.00	250M	208x73x14	H160	350	1005	200	250	180	730	210	1660	680	830	240	525	1025	180	1920	2080	M16x250
	75.00	280S	215x74x14	H180	350	1150	200	250	180	740	210	1730	690	865	240	525	1025	180	1990	2150	M16x250
	90.00	280M	215x74x14	H180	350	1195	200	250	180	740	210	1730	690	865	240	525	1025	180	1990	2150	M16x250
	110	315S	230x82x16	H200	350	1405	200	250	180	820	230	1840	760	920	245	545	1045	180	2150	2300	M18x350
132	315M	230x82x16	H200	350	1485	200	250	180	820	230	1840	760	920	245	545	1045	180	2150	2300	M18x350	

CBTA Size	Motor		Base plate No.	Cplg.	Weight kg		DN ₂	DN ₁	a	b ₂	v	e ₁	e ₂	v ₂	f ₁	h ₃	h ₄	x	w*	w ₁	Rag bolt
	kW	size			pump	Unit*															
200500	75.00	280S	217x84x14	H180	400	1200	200	250	200	840	210	1750	790	875	260	595	1155	180	2010	2170	M16x250
	90.00	280M	217x84x14	H180	400	1245	200	250	200	840	210	1750	790	875	260	595	1155	180	2010	2170	M16x250
	110	315S	232x85x16	H200	400	1475	200	250	200	850	230	1860	790	930	265	615	1175	180	2152	2320	M18x350
	132	315M	232x85x16	H200	400	1555	200	250	200	850	230	1860	790	930	265	615	1175	180	2152	2320	M18x350
	160	315L	246x85x16	H200	400	1705	200	250	200	850	250	1960	790	980	265	615	1175	180	2312	2460	M18x350
	200	315L	246x85x16	H200	400	1810	200	250	200	850	250	1960	790	980	265	615	1175	180	2312	2460	M18x350
200630	160	315L	260x131x20	H200	400	2070	200	250	200	870	250	2080	810	1040	265	615	1175	180	2450	2580	M18x350
	200	315L	260x131x20	H200	900	2570	200	250	250	1310	270	2060	1240	1030	315	830	1580	180	2452	2600	M20x400
	250	315	274x131x20	H225	900	2834	200	250	250	1310	270	2200	1240	1100	315	830	1580	180	2590	2740	M20x400
	315	315	274x131x20	H225	900	3035	200	250	250	1310	270	2200	1240	1100	315	830	1580	180	2590	2740	M20x400
	355	355	296x131x20	H250	900	3415	200	250	250	1310	290	2380	1240	1190	320	830	1580	180	2815	2960	M20x400
	400	355	296x131x20	H250	900	3515	200	250	250	1310	290	2380	1240	1190	320	830	1580	180	2815	2960	M20x400
250315	45.00	225M	203x80x14	H140	425	980	250	300	250	800	210	1610	750	805	310	545	1105	180	1890	2030	M16x250
	55.00	250M	215x80x14	H160	425	1070	250	300	250	800	210	1730	750	865	310	545	1105	180	1990	2150	M16x250
	75.00	280S	222x88x14	H180	425	1240	250	300	250	800	230	1760	750	880	310	545	1105	180	2060	2220	M16x250
	90.00	280M	222x88x14	H180	425	1285	250	300	250	800	230	1760	750	880	310	545	1105	180	2060	2220	M16x250
	110	315S	237x82x16	H200	425	1485	250	300	250	820	230	1910	760	955	315	565	1125	180	2202	2370	M18x350
250400	45.00	225M	208x88x14	H140	465	1020	250	300	250	880	210	1660	830	830	310	570	1170	180	1940	2080	M16x250
	55.00	250M	220x88x14	H160	465	1130	250	300	250	880	230	1740	830	870	310	570	1170	180	2040	2200	M16x250
	75.00	280S	227x88x14	H180	465	1285	250	300	250	880	230	1810	830	905	310	570	1170	180	2110	2270	M16x250
	90.00	280M	227x88x14	H180	465	1330	250	300	250	880	230	1810	830	905	310	570	1170	180	2110	2270	M16x250
	110	315S	242x89x16	H200	465	1565	250	300	250	890	250	1920	830	960	315	590	1190	180	2252	2420	M18x350
	132	315M	242x89x16	H200	465	1645	250	300	250	890	250	1920	830	960	315	590	1190	180	2252	2420	M18x350
250500	75.00	280S	227x93x14	H180	590	1415	250	300	250	930	230	1810	880	905	310	620	1290	180	2110	2270	M16x250
	90.00	280M	227x93x14	H180	590	1460	250	300	250	930	230	1810	880	905	310	620	1290	180	2110	2270	M16x250
	110	315S	242x94x16	H200	590	1705	250	300	250	940	250	1920	880	960	315	640	1310	180	2252	2420	M18x350
	132	315M	242x94x16	H200	590	1785	250	300	250	940	250	1920	880	960	315	640	1310	180	2252	2420	M18x350
	160	315L	256x94x16	H200	590	1935	250	300	250	940	250	2060	880	1030	315	640	1310	180	2412	2560	M18x350
	250630	200	315L	262x127x22	H200	965	2675	250	300	250	1270	270	2080	1200	1040	315	810	1560	180	2452	2620
250		315	275x127x22	H225	965	2930	250	300	250	1270	270	2210	1200	1105	315	810	1560	180	2590	2750	M20x400
315		315	275x127x22	H250	965	3150	250	300	250	1270	270	2210	1200	1105	315	810	1560	180	2590	2750	M20x400
355		355	298x127x22	H250	965	3560	250	300	250	1270	290	2400	1200	1200	320	810	1560	180	2815	2980	M20x400
400		355	298x127x22	H250	965	3660	250	300	250	1270	290	2400	1200	1200	320	810	1560	180	2815	2980	M20x400
500		355	298x127x22	**	965	**	250	300	250	1270	290	2400	1200	1200	320	810	1560	**	**	2980	M20x400
300400	75.00	280S	232x94x14	H180	620	1440	300	350	300	940	230	1860	890	930	360	595	1265	180	2160	2320	M16x250
	90.00	280M	232x94x14	H180	620	1485	300	350	300	940	230	1860	890	930	360	595	1265	180	2160	2320	M16x250
	110	315S	247x95x16	H200	620	1720	300	350	300	950	250	1970	890	985	365	615	1285	180	2302	2470	M18x350
	132	315M	247x95x16	H200	620	1800	300	350	300	950	250	1970	890	985	365	615	1285	180	2302	2470	M18x350
	160	315L	261x95x16	H200	620	1950	300	350	300	950	270	2070	890	1035	365	615	1285	180	2462	2610	M18x350
	200	315L	261x95x16	H200	620	2055	300	350	300	950	270	2070	890	1035	365	615	1285	180	2462	2610	M18x350
300500	250	315	273x95x16	H225	620	2310	300	350	300	950	270	2190	890	1095	365	615	1285	180	2600	2730	M18x350
	315	315	273x95x16	H250	620	2525	300	350	300	950	270	2190	890	1095	365	615	1285	180	2600	2730	M18x350
	110	315S	247x103x16	H200	805	1955	300	350	300	1030	250	1970	970	985	365	670	1340	180	2302	2470	M18x350
	132	315M	247x103x16	H200	805	2035	300	350	300	1030	250	1970	970	985	365	670	1340	180	2302	2470	M18x350
	160	315L	261x103x16	H200	805	2185	300	350	300	1030	270	2070	970	1035	365	670	1340	180	2462	2610	M18x350
	200	315L	261x103x16	H200	805	2290	300	350	300	1030	270	2070	970	1035	365	670	1340	180	2462	2610	M18x350
350400	250	315	273x103x16	H225	805	2545	300	350	300	1030	270	2190	970	1095	365	670	1340	180	2600	2730	M18x350
	315	315	273x103x16	H250	805	2760	300	350	300	1030	270	2190	970	1095	365	670	1340	180	2600	2730	M18x350
	355	355	296x104x18	H250	805	3215	300	350	300	1040	290	2380	980	1190	370	690	1360	180	2825	2960	M18x350
	400	355	296x104x18	H250	805	3315	300	350	300	1040	290	2380	980	1190	370	690	1360	180	2825	2960	M18x350
	500	355	296x104x18	**	805	**	300	350	300	1040	290	2380	980	1190	370	690	1360	**	**	2960	M18x350
	350400	132	315M	245x110x18	H200	865	2235	350	400	300	1100	250	1950	1040	970	365	735	1435	180	2297	2450
160		315L	260x110x18	H200	865	2285	350	400	300	1100	270	2060	1040	1030	365	735	1435	180	2457	2600	M18x350
200		315L	260x110x18	H200	865	2390	350	400	300	1100	270	2060	1040	1030	365	735	1435	180	2457	2600	M18x350
250		315	275x110x18	H225	865	2645	350	400	300	1100	270	2210	1040	1105	365	735	1435	180	2595	2750	M18x350
315		315	275x110x18	H250	865	2860	350	400	300	1100	270	2210	1040	1105	365	735	1435	180	2595	2750	M

DATA REGARDING SIZE - ORDER HINTS

Position	Characteristics	Code	Explanation
1-3	Type	CBT	horizontal, single - stage volute casing pump with design features and nominal rating to ISO2858/EN22858 based on the process principle.
4	Construction	A or E	
5-7	Size	100 - 350	Diameter of discharge nozzle
8-10	Diameter of impeller	160 - 630	
11	Hydraulic	A D E F	1° hydraulic (simple volute) 3° hydraulic (double volute) 4° hydraulic with diffuser type E 5° hydraulic with diffuser type F
12	Bearing configuration	R	One deep groove ball bearing on the pump side, two angular ball bearings on the coupling side, oil lubrication
13-15	Shaft sealing (*)	021 041 501 521 541 BK3 BKS	Uncooled stuffing box with external sealing/flushing. (Inlet) Uncooled stuffing box, self-sealing. Internal connection. Stuffing box with external intensive cooling (In-and Outlet) Stuffing box with cooling/heating jacket back cover and external inlet. Stuffing box with cooling/heating jacket back cover and internal sealing. Mechanical seal MG1-G60 – AQ1EGG Mechanical seal MG1-G60 – Q1Q1VGG
16-17	Material	0B 0G 1A 1G 2A 2G 4B F1	Wetted parts of cast iron GG 25 Wetted parts of cast iron GG 25, impeller GGG (only for impeller dia. 630) Wetted parts of GGG, impeller cast iron Wetted parts of GGG (only for impeller dia. 630) Wetted parts of cast steel Wetted parts of cast steel, impeller GGG (only for impeller dia. 630) Wetted parts of stainless steel Wetted parts and shaft of duplex steel
18	Casing seal	P V E 2 3 4	O-rings Perbunan [®] O-rings Vitón [®] O-rings EPDM flat seal PTFE GF 25 flat seal synthetic fiber flat seal graphite/stainless steel
19	Oil lubrication Oil bath cooling Bearing monitoring	A B C D	Constant level oiler (CLO) CLO with oil bath cooling CLO with bearing monitoring CLO with oil bath cooling and bearing monitoring
20	Flange ratings	0 1 2 3 4 5	Flanges to DIN PN 16 Flanges to DIN PN 25 Flanges drilled to DIN PN 40 Flanges drilled to ANSI RF 150 Flanges drilled to ANSI RF 250 Flanges drilled to ANSI RF 300

(*) Not all of the shaft sealing executions may be available for all sizes

STERLING



Sterling Fluid Systems

www.sterlingfluidsystems.com